

2020/2021

# solutions

gear manufacturing technology magazine

**Game Changer:  
Hard Finishing  
With 100% Quality  
Inspection**

## **Technology in Action**

Forest City Gear Shapes Faster  
Power Skiing of Larger Gears  
Iwasa Tech Excels at Inspection

### **KISSsoft**

Optimizing Manufacturability

### **GAMA 3.2**

Inspection Gets Smarter

Total Gear Solutions

**Gleason**

# Welcome to Gleason



John J. Perrotti

President and  
Chief Executive Officer

Dear Valued Customers:

These past months have been the most challenging and turbulent in a generation. The global economic environment has never been more unpredictable.

In times such as these, with the unprecedented convergence of powerful social, political, health and economic forces, companies must rethink their strategies, and put tradition to the test.

Gleason is no different. While we have been proactive, for example, in the pursuit of the new technologies needed for eDrives, no one could have predicted the arrival of COVID-19 nor its impact on the way we interact with customers, suppliers and employees. It is a testament to the dedication of our global team, and their willingness to adapt to change, that we have swiftly adapted to many new ways of doing business, while at the same time working to make our customers' lives as easy and convenient as possible. These new methodologies have included everything from virtual machine acceptances to live product demonstrations, to free services like our new Gear Trainer Webinars and support apps such as the Gear Calculator App.

Going forward, there is a sense of both urgency, and great optimism, in the work our company is doing to prepare for a future where a premium will be placed on innovation and adaptability to change. Our new manufacturing technologies are tailor-made to deliver much-needed design and manufacturing solutions for eDrive, aerospace, energy, construction and farming

industries; always evolving with more efficient and more resource-saving technologies supported by cloud-based or local analysis and optimization. With Gleason's Closed Loop and in-process inspection coupled to manufacturing, for example, we offer customers a real 'game changer' in terms of productivity and quality control – with optimization feedback in real time, accompanied by solutions for smart tooling setup and optimized machine performance.

These are difficult times to be sure, but if history has told us anything, it's that amazing progress will be made as a result. We believe that 2021 reinvestment goals are critical to compete; we will be at your side with the broadest portfolio of gear solutions including design, manufacture and inspection. With our global footprint we strive to be your partner to help meet the challenges of tomorrow.

Yours sincerely,

A handwritten signature in black ink, appearing to read 'J. Perrotti', written in a cursive style.

- 04 Cover Story: Hard Finishing with 100% Gear Inspection
- 08 Faster Shaping Lands at Forest City Gear
- 12 Power Skiving for Larger Gears
- 14 Inspection Never Gets Old at Iwasa Tech
- 18 Introducing: The Diff<sup>2</sup> e-drive
- 20 Best In Class: The New and Improved 280G
- 24 New Pitch Line Fixture Minimizes Runout
- 26 KISSsoft Connects Design to Manufacturing
- 30 GAMA™ 3.2 Inspection Software: Most Powerful Version Yet
- 32 Inspection Solutions for Quieter Gears
- 34 Introducing Gleason Connect Cloud
- 36 Now Streaming: Gear Trainer Webinar Series
- 38 Gear Design on the Go!
- 39 Gear Calculations: There's an App for That



© 2020 Gleason Corporation. All Rights Reserved.  
 solutions magazine is published regularly throughout the year, and distributed worldwide.  
 Please address correspondence to: Christian Albrecht, Editor solutions magazine.  
 Gleason Corporation, 1000 University Ave., P.O. Box 22970, Rochester, NY 14692-2970 U.S.A.,  
 +1 585-473-1000 • www.gleason.com • sales@gleason.com



# Hard Finishing with 100% Quality Inspection

Gleason's vision becomes reality: The world's first system for hard finishing of gears with gear measurement in-process and Closed Loop feedback.

**A**t the 2019 MPT show in Detroit, Michigan USA, Gleason unveiled its new Hard Finishing Cell (HFC) with integrated inspection of up to 100% of all gears in process. For the first time, the Gleason HFC combines the latest Threaded Wheel Grinding with revolutionary new GRSL Gear Rolling System with Integrated Laser

Technology in a single system to finally address – and solve – the challenge of random gear inspection that has long existed in high volume gear production.

### 95% of Gears Go Untested

In conventional gear manufacturing, quality control is carried out only

randomly. This is due to the significantly longer measuring times required in comparison to the actual production time and limited measuring capacity. It is not unusual in continuous generating grinding to measure only one or two components per dressing cycle. Depending on the dressing cycle, this corresponds to only about 5% of the



components actually produced. In order to guarantee an almost 100% reliability, statistics are instead used to validate most of the gears produced. Typical measuring characteristics can be represented and statistically evaluated on a Gaussian bell curve. By deliberately narrowing down the tolerances on the actually measured components, it is possible to guarantee compliance with the actually required drawing tolerances with a sufficiently high probability (typically > 99.99%). This method is commonly used for machine and process capability studies and is recognized worldwide. The machine or process capability values  $cm_k$  and  $cp_k$  frequently taken as a basis are usually above 1.67. Statistically, the reject rate is only 0.57 components per 1 million manufactured components, but

this means that only about 50% of the actually intended drawing tolerances are available as manufacturing tolerances.

**A Better Way**

In today's world, that's not good enough. The constantly increasing power density of gears and the growing importance of noise behavior are leading to increasingly tight tolerances. Clearly, the heavy reliance on statistics poses a significant problem for a growing number of gear manufacturers.

Gleason's new GRSL roller testing device with integrated optical measuring technology opens up a world of new possibilities by reducing measuring time so that it can realistically be done within the actual production time. This provides

the possibility of up to 100% inspection of all manufactured components. End result? There is no need for additional narrowing of tolerances and the 100% inspection of all manufactured components can be accomplished in-process.

**Many Technologies, One System**

The HFC thus offers significant added value. It's a fully automated system with robot loading that integrates modules for auxiliary processes in order to meet specific customer requirements easily and flexibly. The complete process sequence includes gear grinding, washing, laser marking, measuring and part handling in a stackable basket system. The HFC approach can be



# Hard Finishing Cell

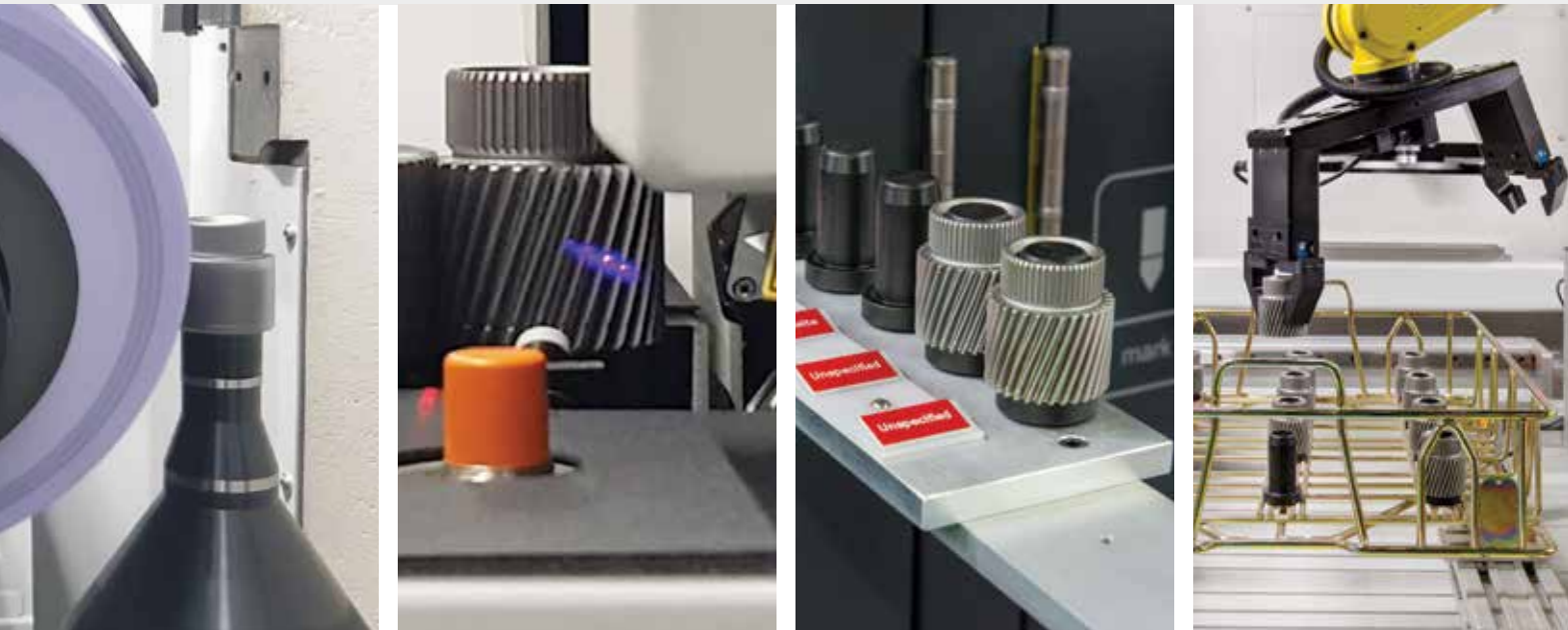

The Hard Finishing Cell is the world's first fully-automated, closed loop manufacturing system including revolutionary in-line gear checking with real-time analysis and automatic feedback of corrections to the Threaded Wheel Grinding Machine.

taken with any desired process, with a single system replacing a number of machines in a Closed Loop system.

HFC's 100% inspection capability results from the new Gleason GRSL analytical and composite inspection unit which is fully integrated into the system. The component to be tested is loaded by the robot onto the double-flank rolling test device. During the gear inspection, a laser scanner is used to measure all gear characteristics. Thus all relevant information for profile, pitch and runout and, if desired, lead measurement is available. This is done for each tooth and not, as is usually the case, only on four teeth distributed over the circumference.

Deviations are fed back directly into the production machine by means of a closed correction loop. Both fully automatic correction and real-time adjustment of the corresponding parameters can be achieved. Compare that to the conventional measurement process in the quality lab, where 45 to 60 minutes may well pass between removing the component

from the machine and providing the measurement result. With HFC's in-process inspection and Closed Loop, the desired correction ensuring optimum quality during the ongoing production process is much faster.

Components whose characteristics lie outside the tolerances are automatically rejected. It is also possible to create extensive trend analyses of individual features and perform further gear noise analysis.

## 4.0 Inside

In addition to the many analysis options that the system provides for optimizing workpiece quality, the Hard Finishing Cell is also equipped with the latest 4.0 functions. The Gleason Fingerprint™ Machine Analysis for predictive maintenance allows the user to keep planned machine availability at peak levels. Gleason's "gTools" tool management system reduces operator errors and tool wear and optimizes the use of tools. Of course, the HFC

is equipped with the latest Gleason accessories, including the Quik-Flex® Plus modular fixture, which allows changeovers in minutes, and Gleason dressing tools.

## In Summary

HFC is indeed a highly desirable solution for many industries and applications where consistent high quality is important, such as the production of high precision e-drive gears with minimal noise characteristics. A single system for the fast and high-quality production with 100% gear inspection, long the dream of many customers, is now reality.



**Dr. Antoine Türich**  
Director Product  
Management of Hard  
Finishing Solutions  
Gleason Corporation

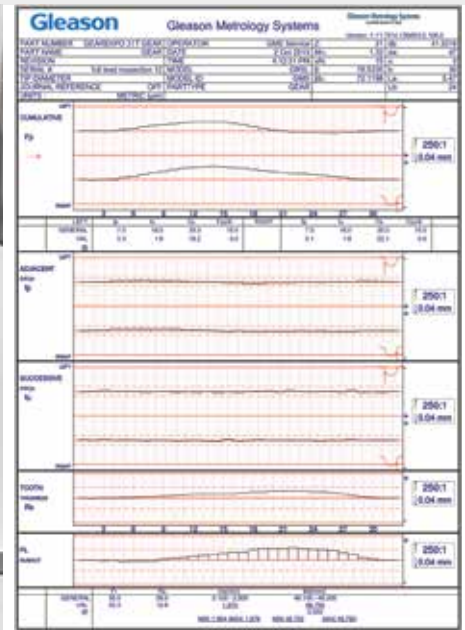

GRSL laser scanning now makes possible 100% part analysis and validation in seconds, with realtime feedback and advanced analytics including profile, lead and pitch measurement (chart shown at right) and gear noise analysis.

## System or Stand-Alone: GRSL Delivers Unprecedented Speed and Flexibility

GRSL (Gear Rolling System with Laser) for the first time combines composite testing with advanced analytical non-contact laser technology in a single system. Cycle times for non-contact index, involute and lead inspection are up to 10 times faster than conventional systems for the analysis of cylindrical gears from .4 to 7.2 module, up to 250 mm (10") in diameter.

### Unprecedented Inspection Speed

- Performs non-contact index and profile inspection up to 1600% or more faster than conventional machines.
- Performs composite testing and index and profile inspection in the same test cycle.

### Greater Flexibility

- View profile characteristics for every tooth for spur and helical gears: fko, fHa, Fa, ffa, faHm, Vaf, others.
- View index: Fp, fp, Fr and runout Fu.
- View composite: Nick, TCV, T2T, Average DOP, Average Circular ToothThickness, Fi" and fi".
- Uses familiar Gleason GAMA™/ WINROLL™ software interfaces.
- ISO, DIN and AGMA analysis charting.
- Easily integrated into a complete system or used as a stand-alone machine.



Watch the HFC in action

# Faster Shaping Lands

at **FOREST CITY GEAR**

Forest City Gear is boldly going where no gear jobber has gone before, with the first Gleason GP300ES Gear Shaping Machine featuring 40% faster cutter spindle speed.

The search for intelligent life on Mars will take a big leap forward on February 18, 2021 when NASA's latest Mars Rover, called Perseverance, touches down. Its mission? To seek signs of ancient life and collect rock and soil samples for possible return to Earth – and pave the way for future human exploration. It's the most ambitious of NASA's Mars missions, with a larger, more sophisticated Rover that builds on the lessons learned by previous Rovers dating back to 1997.

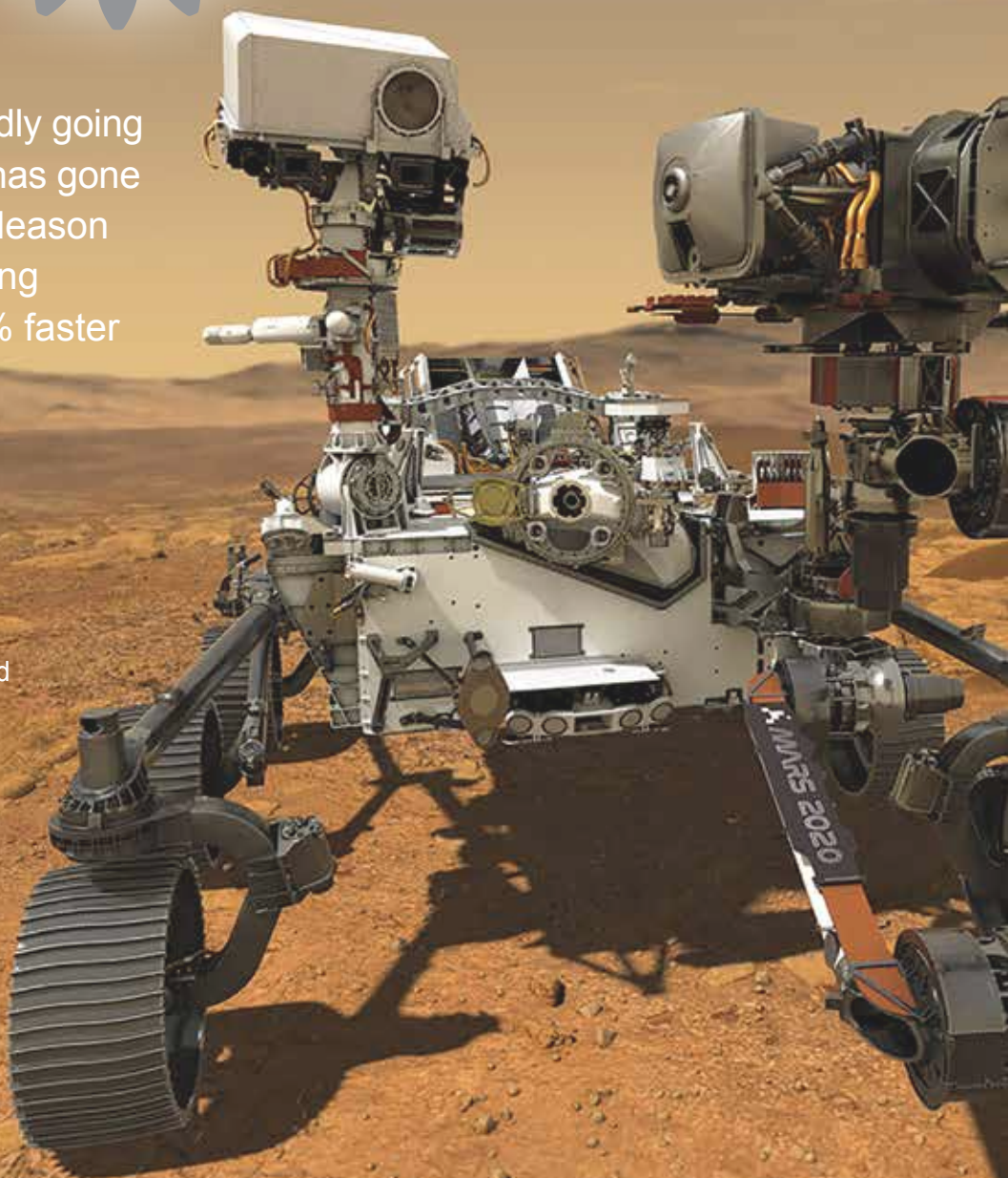





“

I believe this machine really marks the beginning of a new chapter in shaping, both for the industry and Forest City Gear.

Jared Lyford  
Director of Operations  
Forest City Gear

”



Fortunately for NASA, 'intelligent life' can be found a lot closer to home, at Forest City Gear. Gears produced by this well-known precision gear jobber in Roscoe, Illinois USA have been used on every Rover, helping ensure that these vehicles operate dependably, whether traversing the rugged Mars terrain or surviving in temperatures down to minus 130 degrees F.

NASA puts its trust in Forest City Gear, and Forest City Gear in turn trusts Gleason – this time for North America's first GP300ES Gear Shaping Machine with a 1,500 strokes per minute cutter spindle speed that's significantly faster

than anything in its 300 mm diameter size range. The GP300ES is the company's seventh CNC shaping machine, making Forest City Gear one of the largest and most productive shaping resource available for contract gear production. And now, with the GP300ES, one of the fastest.

"We are fortunate to be the first company in North America to put this new, faster GP300ES into production," says Forest City Gear Director of Operations Jared Lyford. "It's a versatile, highly productive machine that's added throughput for our customers seeking faster turn-around and higher quality, particularly for gears that require a unique approach to standard cutting strategies via higher feeds and speeds."

## Improving On the Legacy

According to Mr. Lyford, several important aerospace 'legacy' projects have already benefited from the new Gleason shaping machine. Most notable is a family of aerospace internal and external spur and helical gears, fine and medium pitch, and involute splines – all made from 440C stainless steel. 440C stainless is a grade known for its superior strength and hardness, making it ideal for many aerospace applications. According to Mr. Lyford, the material also can be a challenge to shape. "We could overcome the machinability issues we'd been encountering when shaping these 440 parts by increasing the feeds and speeds to the very upper limits of

our shapers (all of which are the latest models with guideless helical capability) – but then lead integrity would suffer as a result,” recalls Mr. Lyford. “That’s the shaping conundrum in a nutshell: a process ideal for generating critical features against shoulders with limited clearance – but with inherent limits on how fast you can machine.”

With demand growing fast for not only aerospace parts of this type but other

high precision work Forest City Gear went shopping for a new shaping machine – one that ideally could add capacity and shape at much higher speeds than traditionally possible with machines in the 300 mm size range. Fortunately, great minds think alike. Gleason had just improved on one of its ‘legacy’ shaping machines: the popular GP300ES. The new version is designed to address the long-standing shaping conundrum and deliver cutter spindle stroke speeds as high as 1,500/minute.

This is 40% faster than the existing model, and anything else in its size range. In short order, Forest City Gear purchased the first of these new-series GP300ES machines ever to be installed in North America. To accommodate Forest City Gear’s ambitious delivery requirements, Gleason even arranged to have the machine, typically built at its Ludwigsburg, Germany facility, instead assembled at the Gleason headquarters in Rochester, New York USA.



The new design adds leveling wedges with two-chamber air spring elements for greater vibration damping.

# Gear Shaping

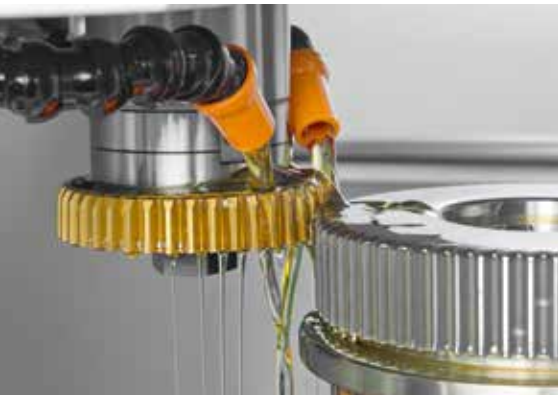

also stiffened the housing sheet metal and added insulation. New leveling wedges with two-chamber air spring elements were added too for greater vibration damping.

## Increased Speed, Problem Solved

Now, with the new GP300ES, Mr. Lyford reports that the problems experienced with the 440 stainless parts have been eliminated. "With the higher surface footages, we can slow the rotary feed enough to put less of a chip load on the cutter to get the required quality but without impacting cycle times," he says. "In fact, we've about doubled surface feet per minute (SFM) for production of almost every part we produce on that machine, while at the same time

reducing chip load. This results in improved quality and extending tool life.

"I believe this machine really marks the beginning of a new chapter in shaping, both for the industry and Forest City Gear."

For more information, contact:

## Forest City Gear

11715 Main Street  
Roscoe, Illinois 61073 USA  
Tel +1 815 623 2168  
info@forestcitygear.com

[www.forestcitygear.com](http://www.forestcitygear.com)

Forest City Gear is applying feed rates twice those of its existing shaping machines to speed production of the precision fine pitch gears it's known the world over for.

## Built for Speed

Compare the earlier GP300ES and the new, faster model side by side and you wouldn't see any obvious differences. While the enhancements made might be subtle, they are significant. Gleason began by developing a new balancing weight that minimizes unbalance for all cutter spindle stroke axis lengths and speed ranges. New control parameters for the stroke and tool back off axes were applied as well to achieve the higher stroke rates. The back off axis also features a new-design back off cam specially designed to operate more reliably at the higher stroke rates.

To accommodate the potential for more noise and vibration, Gleason



# Big Power Skiving at Work

Power Skiving proves its enormous value in the soft cutting of three different large internal gears: faster, higher quality, longer tool life.



The performance benefits of Power Skiving are particularly evident in the production of larger gears, where cycle time savings can add up quickly, and quality parameters have never been higher. To prove the point, we've used our largest Power Skiving Machine, the 600/800PS, to replicate the benefits a Gleason customer is experiencing using Power Skiving for soft cutting three actual workpieces. These represent the extreme working range of our machine.

## Two Steps: Roughing and Finishing

Because the Power Skiving process is inherently much faster than the alternative processes used for soft cutting parts of this type and size we

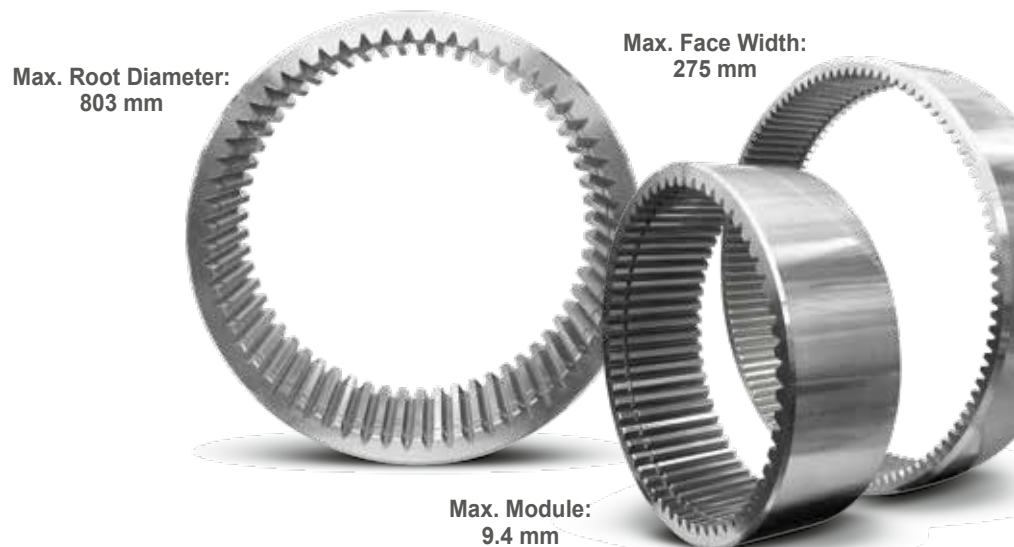



Gleason Roughing Cutter: carbide inserts, AlCroNite® Pro coating, quality class B.

Gleason Finishing Tool: G70 substrate, AlCroNite® Pro coating, quality class AA.

can optimize the process using two steps: roughing, with a cutter with interchangeable carbide inserts for maximum productivity and long tool life; and finishing, with a solid PM tool, designed to produce exceptional quality over its particularly long tool life. Without going into too much detail on the machine itself, it's important to note that the 600/800PS is equipped with automatic tool changing.

A universal workholding system is also used, designed for automatic load and clamping. The system is particularly rigid. The three different families of gears all are radially aligned on their outside diameter and supported on the face with a supporting ring. Additionally, the machine's fixture is designed to efficiently evacuate the large volumes of chips produced in the roughing stage.

We first achieve very high roughing speeds of between 120 and 135 meters per minute with a highly productive carbide-insert tool. With the finishing tool, we make three finishing cuts at similar feedrates: the first in double-flank cutting mode to remove most of the material from both flanks simultaneously, and then the last two single flank cuts, removing minimal material for the best possible quality.

### Built-In Deburring

We also deburr these gears completely in the machine. For deburring of the lower face, we use the back side of the teeth on the finishing cutter. With that we remove the burr with a cutting motion away from the tooth gap in direction of the tooth so that no burr remains bent back into the tooth gap.

For deburring the spring ring grooves, we use a disk located directly under the cutter with radial infeed to feed the disk into groove.

These deburring techniques deliver a completely deburred part with limited effort and no additional tool costs.

### Three Gears, Similar Results

As compared to the traditional processes typically used to soft cut larger gears of this type, the results are apparent, as you can see from the table below. Most impressive are the productivity gains that are possible with a two-step Power Skiving process ensuring the highest possible quality. Floor-to-floor times were far less than the competitive processes, while achieving the longest tool life, lowest tool cost and best overall gear quality.



**Dr.-Ing. Edgar Weppelmann**  
 Manager  
 Application Engineering  
 Gleason-Pfauter  
 Maschinenfabrik GmbH



Watch the latest  
**Power Skiving  
 Webinar**

### Comparison for Different Processes

	Shaping	Profile Milling	Power Skiving (1) Tool	Power Skiving (2) Tools
Cycle Time (hrs)	4.56	1.91	1.36	0.85
No. of Cutters	1	2	1	2
Parts/Cutter	6	12/12	15	40/80
Tooling Cost/Part	\$55.25	\$65.00	\$24.80	\$16.75
Quality	Fair	Good	Good	Best



# Large Gear Inspection Never Gets Old

The first-ever Gleason 3000GMM Gear Metrology System for large gears is going stronger than ever at Iwasa Tech.

More than a decade after installation, Iwasa Tech still relies on the first-ever Gleason 3000GMM, and a second duplicate machine.

Success for many manufacturers hinges on a handful of monumental periods in their history. For Iwasa Tech, a leading Japanese manufacturer of large cylindrical gears and straight and spiral

bevel gears, that time was 2009. That year the company celebrated its 90th Anniversary at a brand new facility in the port city of Chiba just outside Tokyo. The new facility would become the site

for Iwasa Tech's revolutionary approach to producing coarse pitch bevel gears with diameters up to 2,000 mm in low volumes: cutting and hard finishing them on a 5-axis machining center

Iwasa Tech is a major supplier of very large bevel gears, internal and external cylindrical gears for the planetary systems found in wind power turbines and mining equipment, and double-helical gears.

with end mills, and thus eliminating the need for multiple dedicated bevel gear production machines and expensive tooling. The method has enabled Iwasa Tech to react faster to customer demand, whether complete gearsets or a special-design 'one-off' gear or pinion to match an existing gearset, without the development time and cost typically required. Another significant 2009 milestone: installation of a second Gleason 3000GMM Analytical Gear Metrology System to join the first-ever 3000GMM installed a few years before.

## The Iwasa Tech Method

According to company officials, achieving the Iwasa Tech 'method' would have been difficult, if not impossible, without these two Gleason 3000GMMs. The systems seem tailor-made to meet the challenging inspection requirements demanded of this large bevel gear production process. Most obvious is their robust design. The 3000GMMs feature a solid granite base, providing considerably more stability for gears weighing as much as 19,500 kg (42,900 lbs.), as compared to competitive models typically built with cast-iron bases. Their

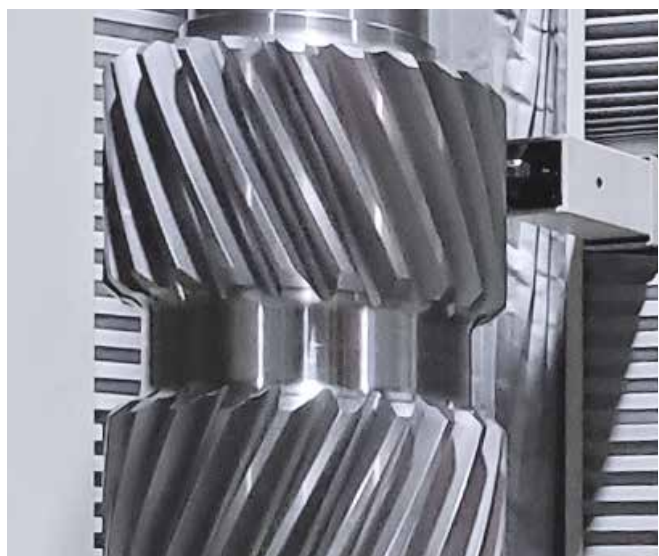



With GAMA, the Windows® based applications suite of software, Creating a new program is as easy as point and click.

Meehanite® cast iron slide assemblies also provide vastly better damping characteristics. The systems are also equipped with heavy duty rotary tables giving them exceptional stiffness and rigidity for workpieces with diameters as large as 3,000 mm. This is capacity to spare for Iwasa Tech bevel gears, and enough to meet the inspection requirements of another significant Iwasa Tech product: the internal ring gears for planetary systems found in wind turbines and mining equipment.

#### **New GAMA Software and Probes**

GMM's are equipped with GAMA™ operating software to simplify programming and completely automate the inspection process. This is the same software suite now in use on the latest generation of GMS systems. GAMA is a powerful Windows® based application that puts a host of features right at the fingertips of the operator in a simple, highly intuitive graphical user interface (GUI). For Iwasa Tech's operators, GAMA makes life easier, whether recalling and loading existing

parts programs or creating new parts programs to meet the considerably different inspection criteria of both bevel gears and internal ring gears.

GAMA also enables Iwasa Tech to connect inspection results to its 5-axis bevel gear machining centers in a Closed Loop. CNC parts programming can be modified and machine corrections made based on actual inspection results – including Tooth Contact Analysis (TCA) – thus speeding the development and production of completely new gears or pinions.

In addition to their periodic software upgrades, Iwasa Tech's GMMs have been equipped with a series of Renishaw SP80H 3D scanning probes, with various stylus sizes and configurations. They can acquire data much faster and more accurately on even the most complex gear tooth profiles, and versions are available for every inspection requirement, including surface finish and noise analysis.

Iwasa Tech gives credit to the years of close service and support provided by Gleason Asia Co., Ltd. for the success

they've had with these two GMMs – still going strong today with many of the same capabilities as the latest Gleason inspection technologies.



#### **Iwasa Tech Co., Ltd.**

62 – 4 Takase-cho Funabashi-shi  
Chiba 273-0014, Japan  
Tel +81-47-420-0103  
info@iwasatech.co.jp

[www.iwasa-tech.com](http://www.iwasa-tech.com)



“ We’ve achieved great things in recent years with the help of these Gleason systems.

Dr. Eng. Isamu Tsuji  
President  
Iwasa Tech

”





# Diff<sup>2</sup> eDrive

Gleason EV transmission design is racing ahead, with the new Diff<sup>2</sup> double differential, designed for ultra-high input speeds.

Today's electric motors for EV's have speeds of 10,000 to 20,000 RPM and are expected to soon increase to 30,000 and 40,000 RPM. This will require transmission ratios more than 20 times higher than what is achieved for vehicles with combustion engines. While a variety of transmission types can be designed for very high reductions, all have significant drawbacks. For example, the typical multi-stage transmission using cylindrical gears would require at least four reduction stages and a prohibitively large and heavy transmission housing. Transmissions using bevel worm gear reductions with ratios of 20 or more in one stage (also known as High Reduction Hypoids or Super Reduction

Hypoids) create high sliding velocities, thus reducing efficiency and increasing the risk of surface damage and premature failure as input increases.

#### Double Differential, Multiple Benefits

A new solution is needed – one that's very compact, with easily produced components and predictable operating conditions. With development of the Diff<sup>2</sup> Gleason has achieved those objectives. The Diff<sup>2</sup> transmission features a double differential: an outer differential unit wrapped around a differential center unit. Both units rotate around the same axes with different speeds. The potential of double differentials as

ultra-high reduction speed reducers is extraordinary. Only the tooth count of the spiral bevel gears in the outer differential unit has to be changed in order to achieve ratios between 5 and 80 – without a noticeable change of the transmission size.

The fact that the carrier rotates with about half of the input speed reduces the relative motion and with it the sliding velocity to 50% as compared to two conventionally meshing bevel gears which roll with the same input speed.

#### Adding an Input for Greater Efficiency

A particularly interesting design configuration is a version with two inputs.

This possibility of a second input allows a variety of input speed combinations with two different prime movers e.g. electrical motors which have different speed and torque characteristics. One motor can be a high torque and low speed motor which runs on a constant speed signal without speed regulation. The second motor would then rotate backwards if an output RPM of zero is required. This configuration can achieve considerable energy efficiencies during rapid acceleration. In case of quick acceleration up to the vehicle's cruising speed, for example, the second motor is first turned off and the stored kinetic energy of the differential gears and the carrier is used for the vehicle acceleration.

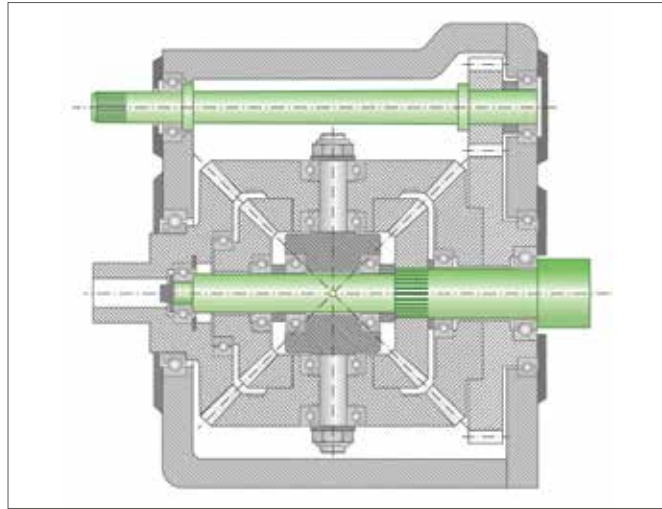

The Diff<sup>2</sup> with two motor input stores kinetic energy, which can be used for rapid acceleration and extending range.

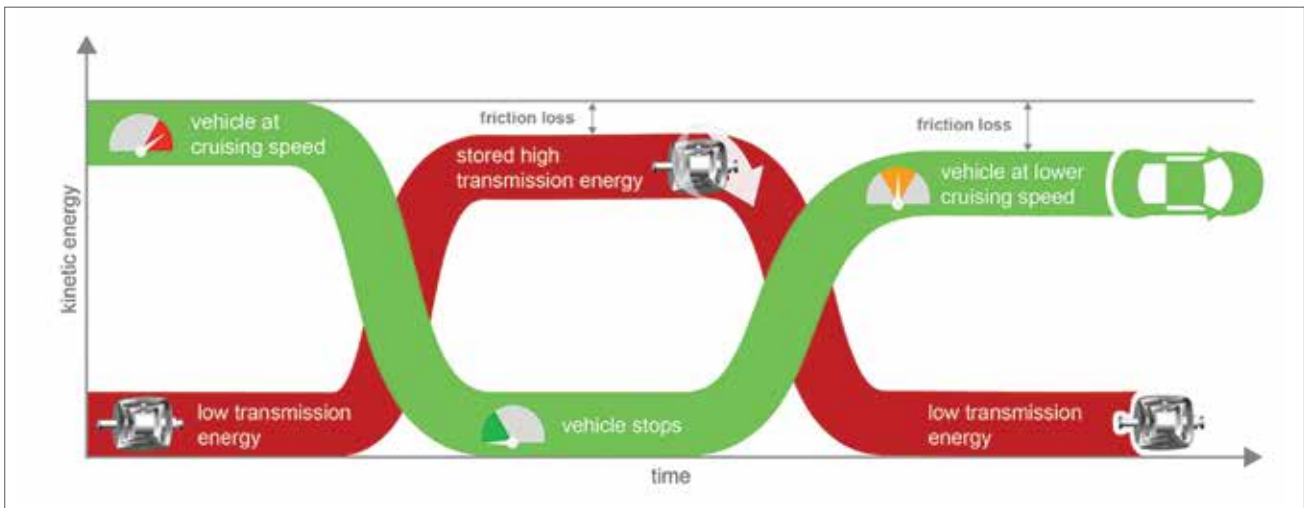

The Diff<sup>2</sup> allows the storage of kinetic energy during gentle driving periods as well as deceleration and braking actions for greater energy efficiency.

## In Summary

Diff<sup>2</sup> offers a number of tantalizing possibilities for EV manufacturers seeking to accommodate the extremely high input RPMs of the very near future. It's compact, highly efficient and easy to manufacture and assemble.



**Prof. Dr. Hermann J. Stadtfeld**  
Vice President  
Bevel Gear Technology  
and R&D  
The Gleason Works



**Dr. Stadtfeld explains the  
Diff<sup>2</sup> Double Differential**

# Best in Class

Whether fine finishing low-noise EV transmission gears in higher volumes or meeting a multitude of jobber versatility requirements, the new and improved Gleason Phoenix® 280G Bevel Gear Grinding Machine outperforms at every level.

Imagine developing the perfect bevel gear grinding machine for today's automotive gears. You want it more reliable than anything on the market, so you start with a simple, extremely rigid monolithic column design cast out of an advanced polymer rather than using cast iron, thus achieving very high thermal stability and damping. Then you create a remarkably clean work area with no visible rails or flat surfaces and free of pipes, wiring and clutter to optimize swarf containment and evacuation. Even the integrated dressing unit retracts completely out of the work zone during grinding.

Your operators have a lot on their hands so you cut their workload and setup times to an absolute minimum with tool-less workpiece, grinding wheel and coolant pipe changeover. You further reduce non-productive time with automatic stock dividing done in parallel with wheel dressing.

Consistent, repeatable quality is paramount. You mount an automatic stock divider in close proximity to the work spindle for automatically determining the tooth slot position of the pre-finished gear for accurate and reliable stock division. You also design



# Bevel Gear Grinding

## Simple by Design

The Phoenix® 280G eliminates pipes, wiring and clutter from the work area so that swarf containment and evacuation is extremely efficient.



your machine with coolant headers that can be set up without tools in seconds, with nozzles that deliver high pressure coolant exactly where it's needed. Header positioning is easily repeatable to achieve exactly the same results on the same parts downstream.

To save on first-part inspection time, you add a wireless, removable probe for fast, convenient checking of flank form, tooth size, pitch error and balancing.

Finally, you want one machine to do it all: Coniflex® grinding of straight bevel gears; Coniface™ grinding of face gears; grinding from solid; and the ability to produce Super Reduction Hypoids and Hypoloids...

It's the perfect machine for today's bevel gear fine finishing requirements. We call it the Phoenix® 280G.

## High-Reliability Dresser



Telescopic dressing unit extends for dressing and retracts during grinding.

## New-Design Coolant Headers



Quick, repeatable tool-less exchange of coolant pipes.

## Stock Division in



Automatic stock divider for a consistently simultaneous with dressing.

### Now, Better Than Ever

The 280G has been a proven solution for several years, employing all of the many features and benefits described above. New users routinely report index quality improvements of 2-3 classes, and the need for far less random parts checking. Now a host of new capabilities is taking the 280G to an even higher level. These include:

- Automatic compensation for workholding runout: 75% less.
- Polish grinding: for low-noise, less fuel consumption.
- UNIMILL™ Universal Milling Method: ideal for prototyping and front hub cutting.
- Next-generation grinding wheels: less wheel wear per part to reduce dressing.
- Automation solutions to increase throughput.
- Closed Loop connectivity with inspection for corrections on the fly.

All types of face and straight bevel gears, SRH, Zerol®, spiral and hypoid gears, couplings and even straight bevel gears with front hubs can be produced.



# Bevel Gear Grinding



Parallel

Consistently high part quality;



First Part Inspection

Integrated workpiece measuring for simple and fast inspection of the first workpiece.



Quick-Change Tooling

Quick-change tooling for workholding and tools.



Different models of Gleason bevel gear grinding wheels cover the widest range of applications, including grind from solid.



Meet the 280G



**Uwe Gaiser**  
Dipl.-Ing (FH)  
Director Product  
Management  
Bevel Gear Solutions  
Gleason Corporation

# Perfect Pitch

Gleason's new Pitch Line Fixture design minimizes runout and helps ensure greater accuracy for hard finishing and inspection.

**G**ear manufacturers are turning to workholding to help reduce cost without compromising quality. Pitch Line Fixtures, for example, can be used to provide a more precise relationship between the pinion/gear member datums and the gear teeth, thus reducing the amount of runout on those datums relative to the pitch diameter (pitch line) of the gear or pinion. Since undesirable runout results from the heat treatment and other manufacturing processes that can cause distortion, Pitch Line Fixtures are particularly well-suited for hard finishing and inspection applications.

## A Better Mousetrap

Gleason has developed a Pitch Line Fixture that will average gear member runout to within 0.0005" (0.0127 mm) to the pitch line – and can be as accurate as 0.0002" (0.005 mm). The application determines the required accuracy. If used in a grinding application where normally 0.004" (0.1016 mm) of stock is removed off each gear flank, then the runout to the bearing journals of 0.0005" (0.0127 mm) would be sufficient. However, if used for hard turning with no subsequent finishing applications or lapping applications, then 0.0002" (0.005 mm) would be more appropriate.

Gleason Pitch Line Fixtures are designed with the pitch pins perpendicular to the gear tooth pitch

diameter for optimized strength, accuracy, and wear. This offers significant advantages over conventional design, where the pins in a pitch line fixture point straight up (parallel to the axis of the part). This can result in a reduction in radial accuracy and stiffness of the centering function. For example, in pinions with a slim pitch angle of, say, 20° the forces on the balls and the pins are not directed in the axial pin direction, thereby reducing the force perpendicular to the pitch angle to only 34% ( $\sin 20^\circ$ ) in the axial pin direction and 94% ( $\cos 20^\circ$ ) perpendicular to the pin. This high perpendicular force will ultimately wear the pin sleeves and also bend the pins. In the case of ring gears this effect is smaller, but the same accuracy and wear issues will occur over time.





(Above) Pitch Line Fixture with spring loaded center in which the part can be positioned off the center and then lowered onto the pins for hard turning, grinding, or inspection.

(Below) Pitch Line Fixture equipped with hydraulic quick change base equipment, for applications where the customer requires fast changeover of multiple part types.

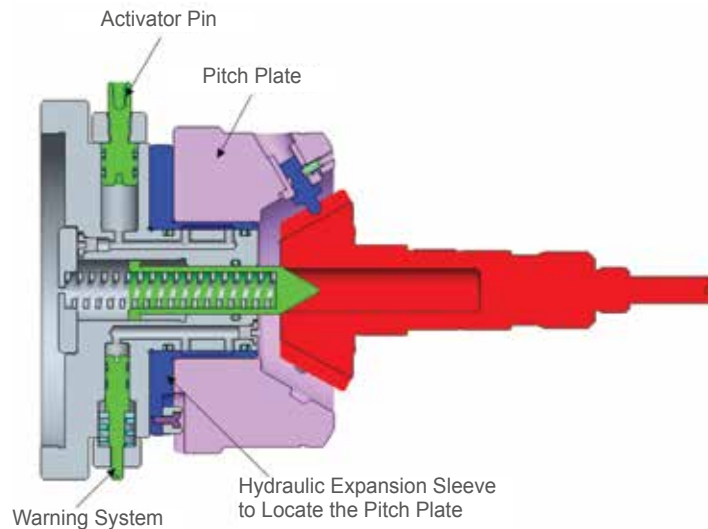
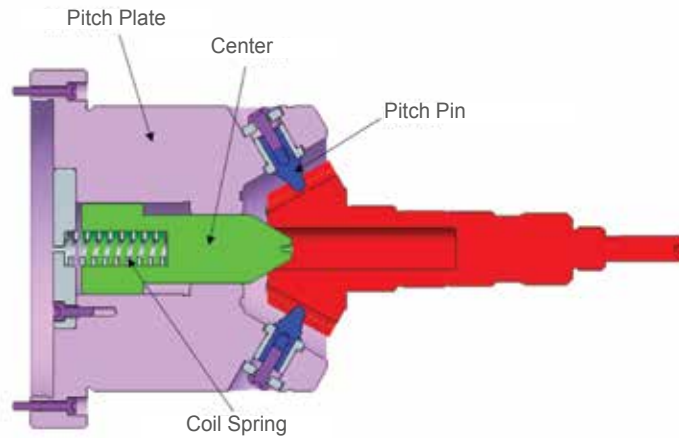

## Application Versatility

Pitch Line Fixtures can be designed to meet the needs of a wide range of customer applications: mechanically or hydraulically actuated, tailstock driven, compatible with quick change base equipment, incorporating a spring loaded pre-centering mechanism, and including mechanically activated holding jaws.

The recommended clamping method is determined by the application. For example, a pinion being held in the Pitch Line Fixture by a tailstock would not require clamp blocks on the pinion head for holding the pinion in place.

For a gear member, straps are often used on the back angle if the process requires that the bore be machined as well as the mounting surface. These pitch line features would be incorporated as required into the design of the fixture.

For more information on how Gleason Pitch Line Fixtures can be used to help reduce cost and improve accuracy in your operations, contact your local Gleason representative.



**Brian Baldeck**  
Manager Design  
Engineering & Assembly  
Tooling Products Group  
Gleason Corporation



**Ian Schickling**  
Lead Tool Design  
Engineer  
Gleason Corporation

# The Power Skiving / KISSsoft Connection



The latest KISSsoft release takes the guesswork out of estimating gear manufacturability, and helps facilitate the use of highly efficient processes like Power Skiving.

Design engineers naturally focus on finding the best possible gear layout, while leaving the manufacturing department to determine the most efficient manufacturing process downstream. Whether a very cost-efficient gear manufacturing process such as Power Skiving can be applied or not depends on certain gear and pinion geometry conditions / interference contours. In many cases, even a small change in the macro geometry at the design stage would permit its use – and lead the way to a much more productive, less costly manufacturing process.

With the KISSsoft 2019 release, it's much easier now for gear designers to estimate the manufacturability of gears using Power Skiving: the tooth geometry is checked regarding machine and tool limitations; the gear can optionally also be checked for collisions with the tool.

Here's how it works:

## Checking Manufacturability of a Single Gear

The checks are activated as part of the manufacturing tab in KISSsoft individually for each gear:

The corresponding settings dialog can be opened using the plus symbol:

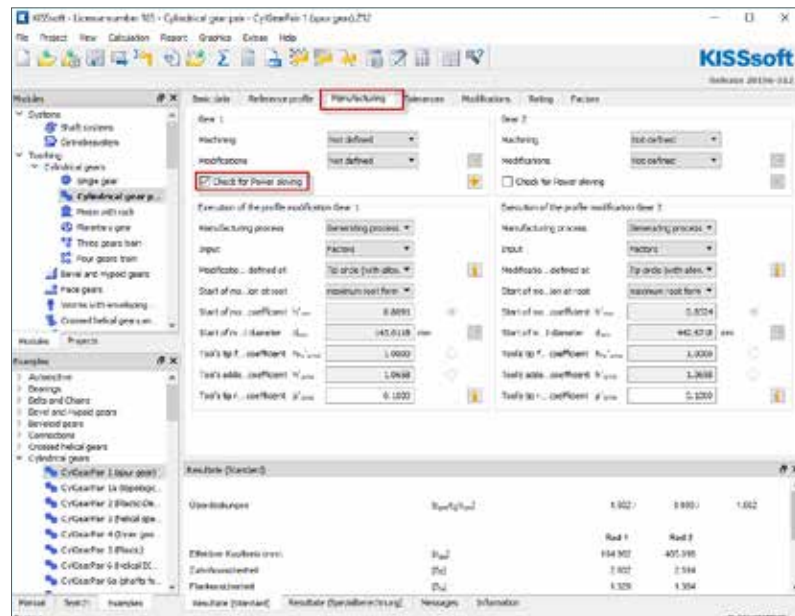

In the dialog, the tool and limitations given by the Power Skiving machine can be specified. Main input values are the minimum and maximum tool diameter and the cross-axis angle. The cross-axis angle can also be defined using the helix angle of the tool.

The number of tool teeth has a default value of 20; an optimal (as large as possible with regard to tool life) can be calculated using the layout button. In case any collision checks are activated, they will be considered here as well.

Collisions scenarios which shall be checked can be activated and parameterized in the section below. In addition, it is also possible to export the corresponding tool-gear helical calculation as a KISSsoft file which can then be opened separately and may be used for visualization or debugging purposes.

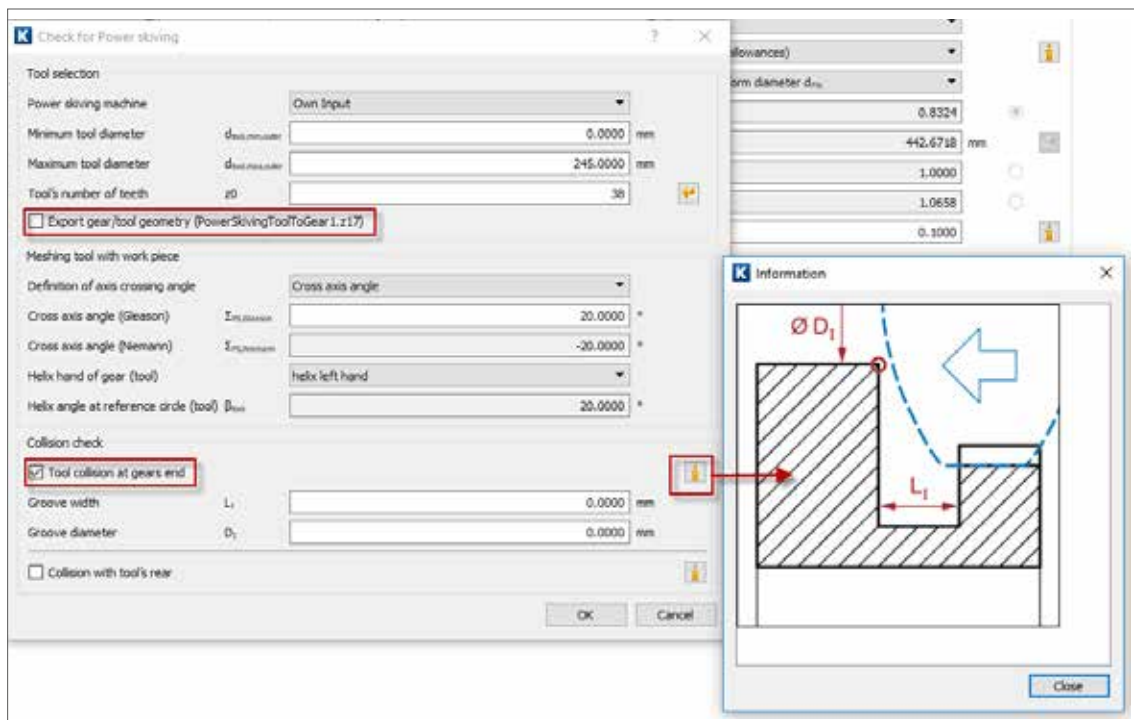
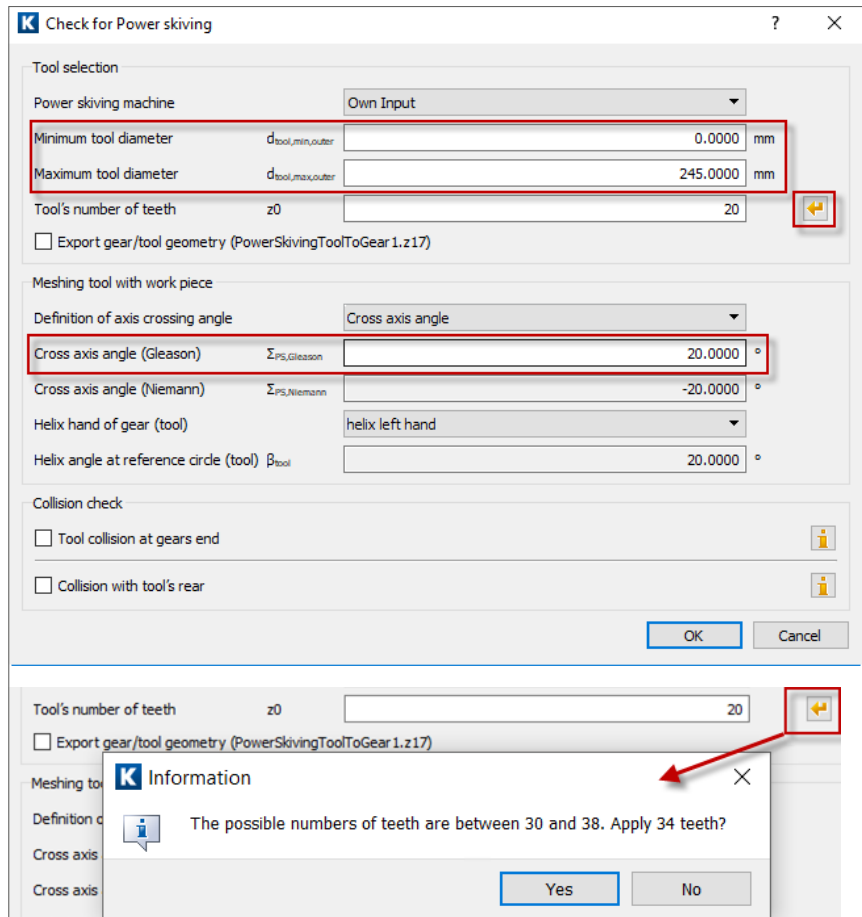



### Manufacturing

Power skiving of Gear 1

Power Skiving: Probably possible

Machine Own Input

Minimum tool diameter	[d <sub>tool,min</sub> ]	0.000
Maximum tool diameter	[d <sub>tool,max</sub> ]	245.000
Skiving tool number of teeth	[z0]	34
Skiving tool helix angle (°)	[β0]	20.000 left
Skiving tool tip diameter (mm)	[da0]	217.092
Axial crossing angle for manufacturing (°)	[Σ0]	20.000
Calculation for tooth thickness/diameter tolerance field 1 / 1 (0: min, 1: mean, 2: max, 3: nominal)		

The manufacturability is then evaluated during each calculation and the results are written into the report:

### Checking for Collisions Behind the Gear (Inner and Outer Gear)

For both inner and outer gears, some space behind the gear is required for the tool over-run. This is mainly depending on the tool diameter and the cross-axis angle. In KISSsoft, a critical diameter and corresponding groove width can be specified and will then be checked against possible collisions.

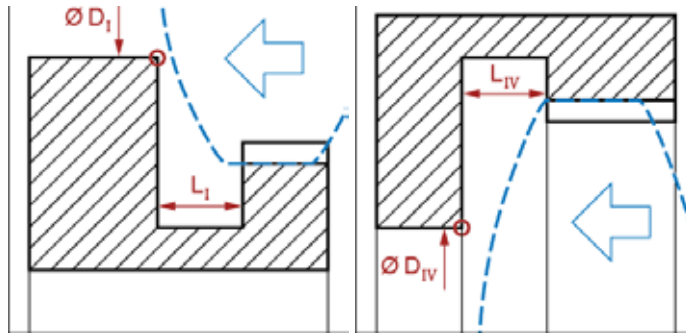

### Checking for Collisions with the Tool Backside (Outer Gear)

For outer gears, an estimate of possible collisions with the tool backside can be performed. This check is based on some qualitative assumptions regarding the tool geometry. In KISSsoft, a critical diameter and corresponding groove width can be specified and will then be checked against possible collisions.

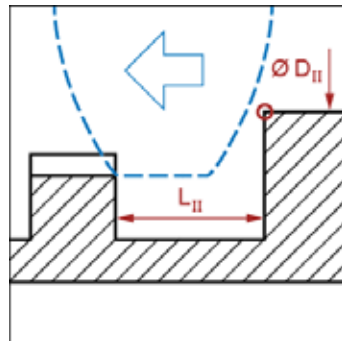

### Checking for Collisions with the Tool Shaft (Inner Gear)

For inner gears, the most critical risk for collisions is between the tool shaft and parts of the gear body. In KISSsoft, the risk of such collisions can be estimated based on qualitative assumptions regarding the tool geometry. A critical diameter and distance to the gear is specified and will then be checked against possible collisions.

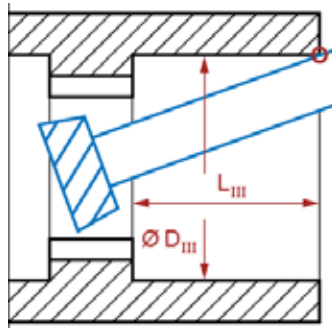

## Considering Power Skiving Manufacturability During Fine Sizing

The fine sizing option in KISSsoft is a very powerful tool. For given overall restrictions, mainly as center distance, face width and reduction ratio, this tool proposes many possible solutions by varying module, helix angle, pressure angle etc. in ranges defined by the user. The checks as specified in the manufacturing settings are also evaluated during fine sizing and may be used as a decision criterion:

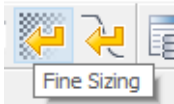

Both the teeth number of the tool and the result of the checks columns if not shown by default can be activated:

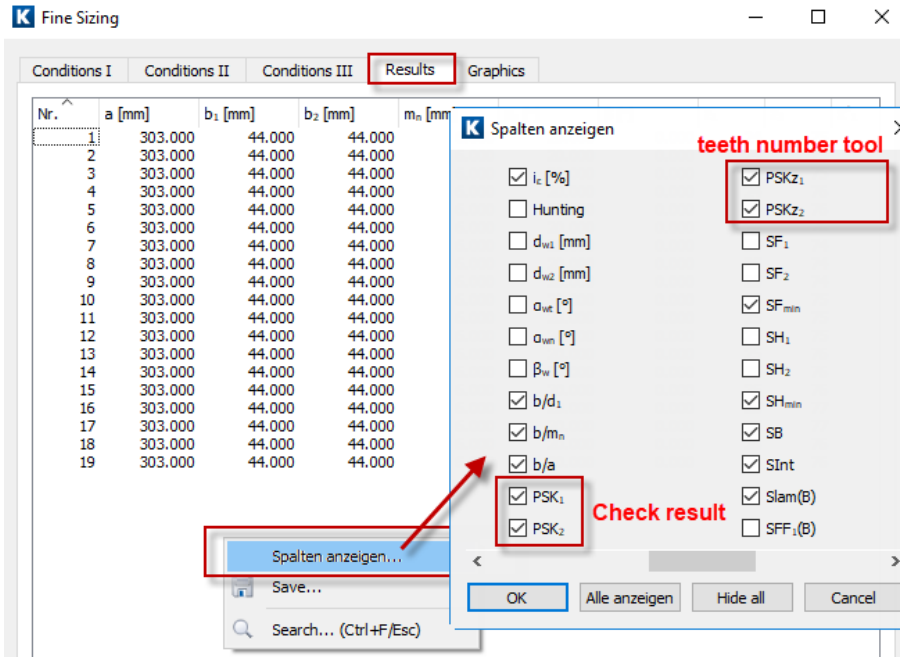

K Fine Sizing													
Conditions I			Conditions II			Conditions III			Results		Graphics		
$\epsilon_a$	$\epsilon_\beta$	$\epsilon_\gamma$	$i$	$i_c$ [%]	$b/d_1$	$b/m_n$	$b/a$	$PSK_1$	$PSK_2$	$PSKz_1$	$PSKz_2$	$SF_{min}$	SH
1.495	0.000	1.495	3.125	2.796	2.796	0.306	7.333	0.145	0	-1	0	20	2.313
1.599	0.000	1.599	3.167	4.167	4.167	0.306	7.333	0.145	0	-1	0	20	2.370
1.583	0.000	1.583	3.167	4.167	4.167	0.306	7.333	0.145	0	-1	0	20	2.349
1.564	0.000	1.564	3.167	4.167	4.167	0.306	7.333	0.145	0	-1	0	20	2.317
1.776	0.000	1.776	3.080	1.316	0.293	7.333	7.333	0.145	0	-1	0	20	2.635
<b>1.662</b>	<b>0.000</b>	<b>1.662</b>	<b>3.040</b>	<b>0.000</b>	<b>0.293</b>	<b>7.333</b>	<b>0.145</b>	<b>3</b>	<b>-1</b>	<b>31</b>	<b>20</b>	<b>2.514</b>	
1.482	0.000	1.482	3.125	2.796	0.306	7.333	0.145	3	-1	29	20	2.292	
1.466	0.000	1.466	3.125	2.796	0.306	7.333	0.145	3	-1	29	20	2.256	
1.400	0.000	1.400	2.960	2.632	0.293	7.333	0.145	3	-1	29	20	2.408	

The value PSK<sub>i</sub> represents the manufacturability result of the check; the PSK<sub>z<sub>i</sub></sub> value the corresponding number of tool teeth. The values of PSK are defined as:

- 2 invalid input
- 1 not tested
- 0 not possible / collision detected
- 1 (currently not used)
- 2 Power Skiving likely (no collision checks activated)
- 3 Power Skiving likely (including activated collision checks)

In the fine sizing solution list, gear variants which can be produced by Power Skiving are clearly indicated in column PSK1 by a '3'.

### Conclusion

The integration of manufacturing information into gear design software reduces cost during the design process by avoiding time-consuming back and forth between the design and manufacturing departments. The challenging task for such software is ensuring the design engineer does

not need specific manufacturing expertise. Otherwise he or she would be overwhelmed and not use such a feature.

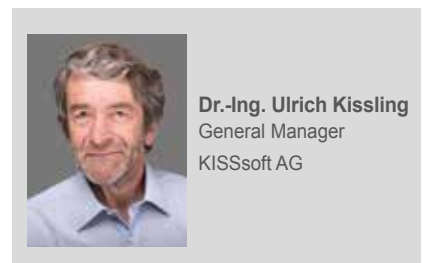

# GAMA 3.2

The powerful, intuitive Interface to optimize every operator's performance.

**G**AMA™ 3.2, the most powerful version ever of the popular Windows® based applications suite, opens a world of new options for growing requirements and greater profits with faster throughput.

### Highlights:

- Supports the complete inspection of all types of gears, including bevel, internal, external, spur and helical gears, shafts and gear cutting tools.
- Supports every optional tactile probing and non-contact laser scanning application for index, lead, and profile analysis sold within GAMA 3.2.
- Multiple waviness analysis tools to help identify the root cause of gear noise.
- Supports connectivity with GEARNET and VDI/VDE 2610 GDE.
- Inspect multiple tip and root diameters at selected involute heights.
- Customizable helix and involute filter parameters for special test for latest ISO gear standards.
- Custom cylindrical gear lead and profile analyses.

### Cylindrical Gear Surface Roughness Measurement

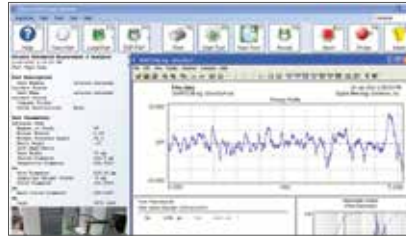

Charts are easily configured to meet AGMA, DIN, ISO, JIS, GOST, China GB, and other standards.

### Bevel Gear Surface Roughness Measurement

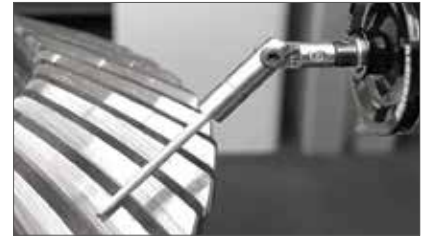

GAMA accommodates Surface Roughness Measurement and clearance moves of a wider range of bevel gear types and sizes, through use of a 45° tilted surface finish probe.

### ENDREM Analysis

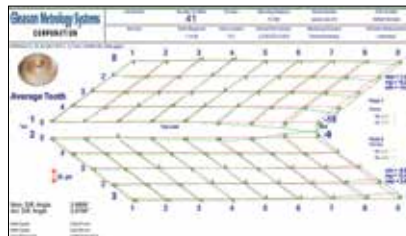

With ENDREM analysis, one measurement flank form can be divided into two parts for better analysis of areas prone to noise.

### CMM-Type Measurement

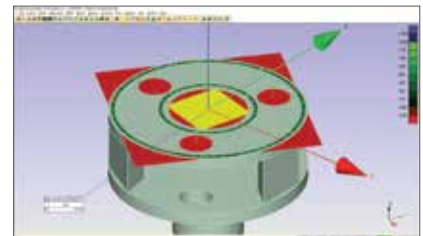

GAMA interfaces gear measurement software and Geometric Dimensioning and Tolerancing (GD&T) capability for integration of non-gear features into the common user interface.



- Expanded bias analysis.
- 'Find Missing Teeth' test option.
- 'Follow Surface journal' scan saves setup time.
- QC bottom center utility saves time for bottom center centering setup.
- Probe accuracy test determines whether a probe tip has a chip or other flaw.
- Probe pad detection for automatic probe changers.
- Automatic multi-tip probe calibration.
- Enhanced QDAS interface.
- Separate flank form deviation tolerances for concave and convex flanks of bevel gears.
- XZ45D surface finish probe can now be used on all bevel gear part types.
- Lead and profile analyses for both maximum and minimum bias tolerances.

## Transmission Gears

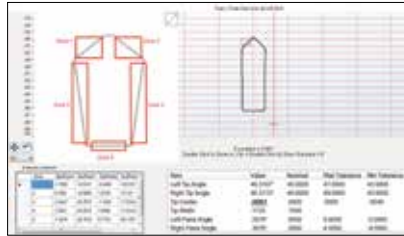

Even transmission gears with irregularly shaped clutch teeth and particularly tight tolerances can be easily inspected for typical features such as roof, sides, symmetry, centrality and more.

## Worm Shaft Inspection



For single-start worm shafts, GAMA 3.2 now gives users the ability to specify the number of axial pitch locations.

## In Summary

With GAMA 3.2, we've addressed the increasing inspection burden being placed on both operator and inspection system, in the lab and on the shop floor. With resources stretched thin and quality objectives raised even higher, there's never been a better time for GAMA 3.2.

## Power Skiving Cutter Inspection



GAMA 3.2 expands the user's ability to inspect a complete range of gear cutting tools, including hobs, shaper cutters, shaving tools – and now all types of Power Skiving cutters, even with a zero outside angle.

## Closing the Loop



With GAMA, Gleason manufacturing machines can be networked in a Closed Loop so corrective actions are fast and accurate.



**Douglas Beerck**  
Vice President and  
General Manager  
Gleason Metrology  
Systems



## GAMA 3.2 Technology Upgrade for Your Existing Systems

GAMA 3.2 Upgrade Package with Windows® 10 operating system makes it easy to take your existing Gleason inspection systems to their highest performance level – all at a fraction of the cost of new equipment. Available for most models of SIGMA, GMM and GMS.



Learn about the  
GMS Series with GAMA 3.2

# Quieter Gears

With the power of GAMA, Gleason inspection systems can apply the most complete range of gear analysis tools to help meet the challenge of producing quieter gears.

**W**ith the surge in electric vehicles and other noise-sensitive applications, gear noise reduction is now of paramount importance. GAMA applications software can apply multiple analysis tools to help identify the root cause of gear noise. The input to these tools is measurement data collected during the inspection of a gear. These tools save the GAMA

user time with extremely user-friendly input requirements and mathematically optimized outputs for ease of interpretation.

#### **New Analysis Tools**

The GMS series are all capable of performing contact analysis, using the same GAMA software. The GMSL

series offers additional benefits, due to its ability to capture high density data at speeds up to 800% faster than tactile probing.

Gleason brings a significant advantage to its customers by combining multiple analysis tools on one platform. With GAMA, you can benefit from any/all of these powerful tools:

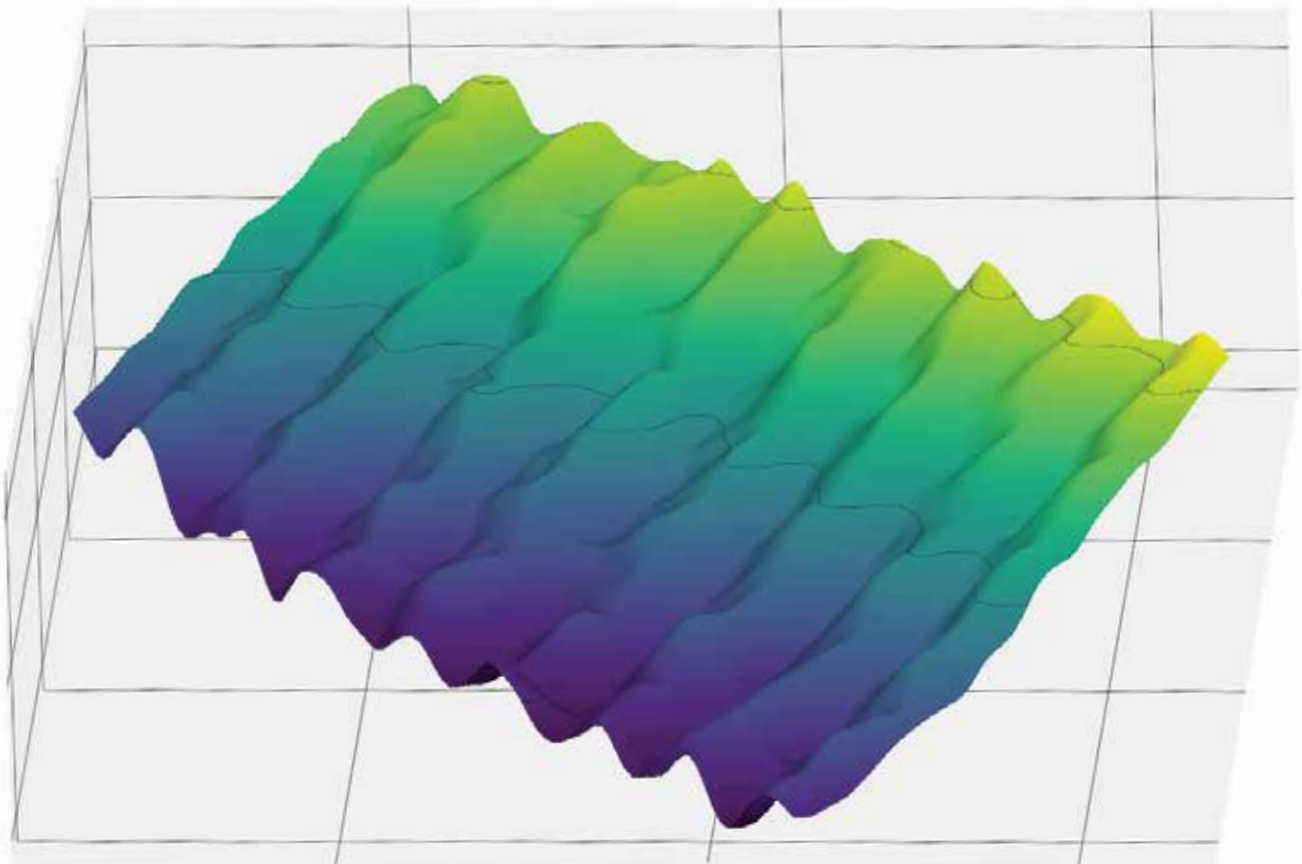



### 1. Fourier Analysis

Compares individual harmonics values of a production gear with a proven reference gear. Fourier Analysis of bearing surface waviness can determine one of the main causes of low-frequency noise in a gear box.

Fourier Analysis

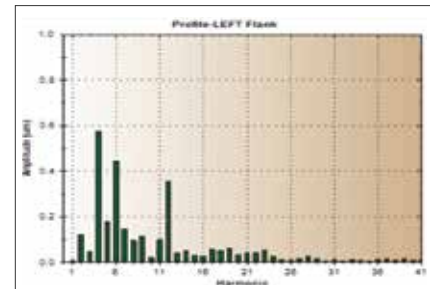
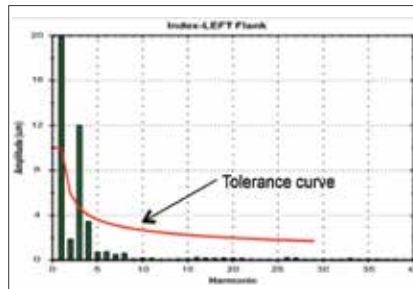

### 2. Tooth Contact Analysis

GAMA tooth contact analysis software computes transmission error along the meshing path, generates ease off topographical charts and identifies misalignments help optimize gear surface geometry.

Tooth Contact Analysis

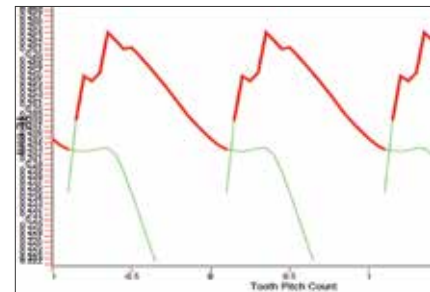
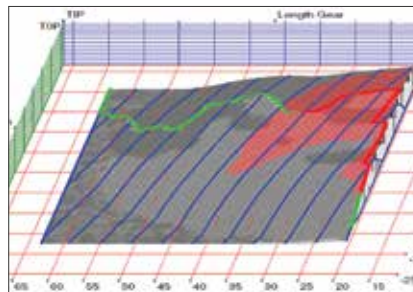

### 3. Surface Finish Analysis

GAMA can analyze measurements up to 72 different surface finish standards with advanced filter methods to analyze high-frequency noise and micro-waviness.

Surface Finish Analysis

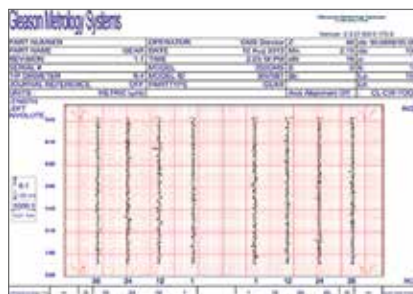

GAMA/KTEPS

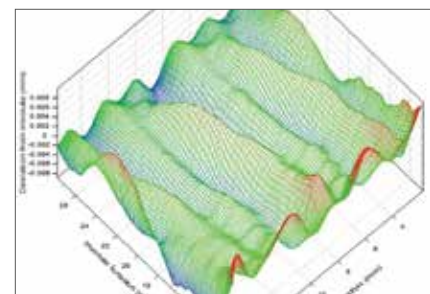

### 4. GAMA/KTEPS

KTEPS uses a revolutionary analysis approach for determining and diagnosing gear noise. GAMA's unique ability to communicate with KTEPS puts this easy-to-use interface at your fingertips.

Loaded Contact Analysis

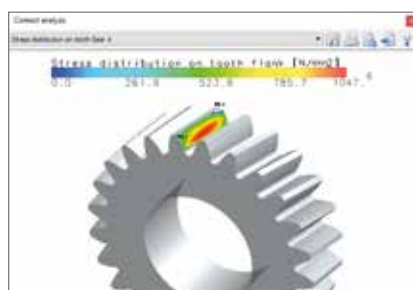

GAMA Advanced Waviness Analysis

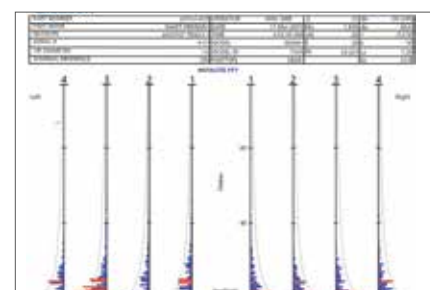

### 5. Loaded Contact Analysis

Design engineers consider the effect of tooth bending under varying load. GAMA can write gear part parameters including tolerances and inspection test data that can be shared with KISSsoft for both gear and gearbox design optimization purposes.

### 6. GAMA Advanced Waviness Analysis

Additional evaluation with FFT is also possible for each single measurement trace. This chart shows the profile, enabling the operator to see in which harmonic the gear will fail (red = out of tolerance).



# Introducing: Gleason Connect Cloud

Your new online portal offering 24/7 service support with A/R conference and video functionality.

**G**leason's new online portal, Gleason Connect Cloud, complements our digital services offering and bundles useful applications in one central location. Now Gleason customers can access machine history, technical documentation, wear and spare parts lists, manuals and service reports from anywhere, at any time. Gleason takes care of the digitalization – you save time for more essential tasks, like keeping your machines up and running productively around the clock.

## Stay Connected

Now, through the Gleason Connect Cloud, you can contact the Gleason expert assigned to your account directly through the ticket system or meet in a service chatroom. The integrated translation function supports a wide range of languages. Or, with Gleason Connect+, take advantage of an extended remote service communication package, including video live streaming featuring augmented reality. Call a virtual service assistant directly to your machine. Alone or in a multi-conference call.

## Unlimited availability

Gleason Connect Cloud is available independent of time and place, anywhere and anytime. Via data glasses, computer or mobile device. All you need is an internet connection and appropriate browser software. Visit [gleason.com](http://gleason.com) to learn more.

**+ Service Portal**



With Gleason Connect+ you get access to our advanced remote service communication package. Data glasses or any mobile device can be used to receive video guided service support in real time.

**+ Document Storage**



The myDocuments storage creates your paperless clean environment and offers access anytime to technical documentation, spare parts lists, service instructions and maintenance reports.

**+ Gleason Shopping**



Our eBay marketplace offers various spare parts and components at favorable terms. Take a look and check out our offers from time to time.

**+ eLearning**



Gleason eLearning supplies online content to enhance professional knowledge, including product and technology training, technical publications, and seminar presentations. This feature is optional.

**+ Service Chat**



As an alternative to phone support, you can contact our service experts using the chat module. Exchange information or transfer documents and images.

**+ Service Ticketing**



Create breakdown reports or place and review the status in real time. Your Gleason service representative will process your lead with the required priority.

**Ask for an online live demo now!**

**[ssstark@gleason.com](mailto:ssstark@gleason.com)**



**Sven Stark**  
 Director  
 Aftersales Service  
 Gleason-Pfauter  
 Maschinenfabrik GmbH

**Gleason Connect+**



Problems in the field can be evaluated 'live' by Gleason experts and resolved in real time with visual directions to the service technician, via Smart Glasses or existing smart device.

**Gleason Fingerprint™**



Gleason Fingerprint™ can be used to retrieve a direct comparison of the machine's current condition and the ideal/normal condition. This can then result in faster, more detailed diagnostics and more proactive service actions.

**Gleason Connect®**



Gleason Connect is also available for older machines, with installation of the Gleason Connect box.

# Now Streaming: 'Gear Trainer' Webinar Series

The popular series gives you expert insight into the most significant challenges facing the global gear industries. All available instantly, from the comfort of your home or office.



**G**leason's "Home Trainer Webinar Series" was a big hit for many in the gear industry working from home during these COVID-19 times. Since the first Home Trainer Webinars began streaming in March 2020, almost 10,000 participants have attended Gleason's Home and Gear Trainer Webinar Series.

Now, this very successful series, renamed the 'Gear Trainer' Webinars, continues to provide an exceptional learning experience in response to design, manufacturing and inspection challenges facing the gear manufacturing industry today. The series covers a variety of topics on

bevel and cylindrical gear manufacturing technology, including gear and transmission design and simulation, metrology, tools, workholding, software and 4.0 production systems.

Gear Trainer Webinars are moderated live by gear technology experts including the possibility to ask questions via the integrated Q&A function. New topics and presenters are added every week, as the live webinar series continues to grow.

Both the new Gear Trainer Webinars and previous Home Trainer Webinars are now streaming at [gleason.com](http://gleason.com). Register today for free access.



In addition to the Gear Trainer Series, visitors to the Gleason training section at [gleason.com](http://gleason.com) will find a wealth of resources to draw on. We have added direct curricula, scheduling, registration for gear technology seminars and training classes.

Classes now include Gleason and KISSsoft seminars and webinars conducted by Gleason Academy sites worldwide, at the customers' facilities or virtually. The Gleason library features books, e-books and technical papers on everything from gear fundamentals to the most advanced technologies, and much more.

The screenshot shows the Gleason website's training section. At the top, there is a navigation menu with links for Home, About, Products, Parts & More, News, Contact, MyGleason, and MyGleason. Below the navigation, there is a large image of a woman in a business suit holding a folder. To the right of this image, the text reads "Gear Technology Seminars & Training Classes with Fixed Dates" and "Gleason seminars and training classes inform about the latest trends in gear manufacturing technology. These training events have fixed dates and are conducted either at Gleason plants, offices or an independent site well suited for training. Search for the topic of interest, the closest training location, and register easily online." Below this text is a button labeled "Locate a Training Event".

Below the woman's image, there is a section for "KISSsoft Training" with the text "Based on the latest software release, KISSsoft training focus on specific modules or dedicated topics. Certified experts explain new design features of KISSsoft/KISSsofts and teach design and calculation skills based on users' requirements and knowhow level." Below this text is a button labeled "Request KISSsoft Training".

To the right of the KISSsoft training section, there is an image of several colorful gears.

Below the KISSsoft training section, there is a section for "Training Classes on Request" with the text "The Gleason Academy offers the industry's widest variety of training classes, covering the full spectrum of bevel and cylindrical manufacturing, automation solutions, metrology, gear and transmission design topics, as well as machine specific trainings." Below this text is a button labeled "Training Classes on Request".

Below the "Training Classes on Request" section, there is a section for "Gleason Library - Fundamentals and Advanced Gear Technology" with the text "Gain specialist gear know-how with gear theory fundamentals and advanced papers about advanced gear manufacturing, including books, eBooks and technical papers." Below this text is a button labeled "Gleason Library".

To the right of the Gleason Library section, there is an image of a gear assembly.

At the bottom of the screenshot, there is a section for "Gleason Academy Locations" with the text "The Gleason Academy provides quality support to companies worldwide."



A green rectangular box containing a QR code on the left and the text "Upcoming Gear Trainer Webinars" on the right.

A portrait of Christian Albrecht, a man with dark hair wearing a dark suit jacket over a light blue shirt. To the right of the portrait, the text reads "Christian Albrecht", "Director Corporate Marketing", and "Gleason Corporation".

# Gear Design on the Go!

The new GEMS® Ecosystem connects gear producers to the powerful design and manufacturing tools they need – anywhere, all the time.

The GEMS Ecosystem is the foundation that supports Gleason 4.0 and provides a complete smart factory solution to the gear industry. It connects the discrete steps of design,

manufacturing, and inspection into an integrated open system that delivers high quality and efficient gear/tool production in both manual and automated environments. It is vitally important to

our customers, as they seek to speed development and production of exciting new products like electric vehicles. The GEMS Ecosystem consists of four major computing platforms:



GEMS Edge

GEMS Edge provides an industrial-grade edge computer for every Gleason 4.0 ready machine. This creates a platform for running gUptime, gTools, gProduction and gProcess software at the machine level and connecting them to other machines and software systems in the customer's factory.

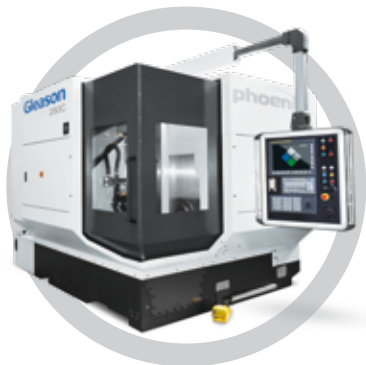

GEMS Enterprise

GEMS Enterprise provides a platform for running apps and services such as System Design, Gear/Tool Design, Gleason 4.0, and Manufacturing solutions on servers and workstations within the customer's facility.



GEMS Mobile

GEMS Mobile provides apps for Gleason 4.0 solutions, service solutions, and shop floor notifications and alerts, to name a few – all through consumer mobile devices such as smart phones and tablets.



# GEMS Cloud

GEMS Cloud provides apps and services such as System Design, Gear/ Tool Design, Gleason 4.0, and Manufacturing solutions from the Cloud. This links with Gleason Business Systems and Data Analytics Systems to offer customers the potential for machine learning and artificial intelligence.



In the past, design applications such as CAGE™, G-AGE®, KISSsoft®, etc. have resided on servers and workstations in the customer's facility. Now, with GEMS Connect, we can run those same applications from the cloud. All application services are available online including real-time software updates and upgrades.

As you might expect, the availability of the GEMS Ecosystem is welcome news to our customers. GEMS Connect, for example, has received very positive feedback from customers seeing demonstrations at our most recent tradeshows. We will be bringing you more information on this development in the months ahead.



**Rakesh Kulkarni**  
Director Digital  
Manufacturing Solutions  
Gleason Corporation

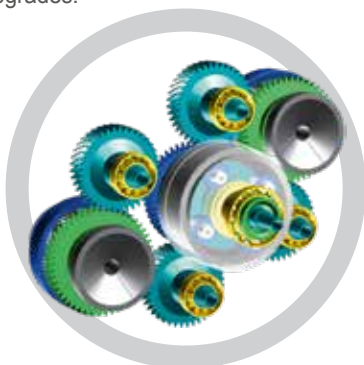

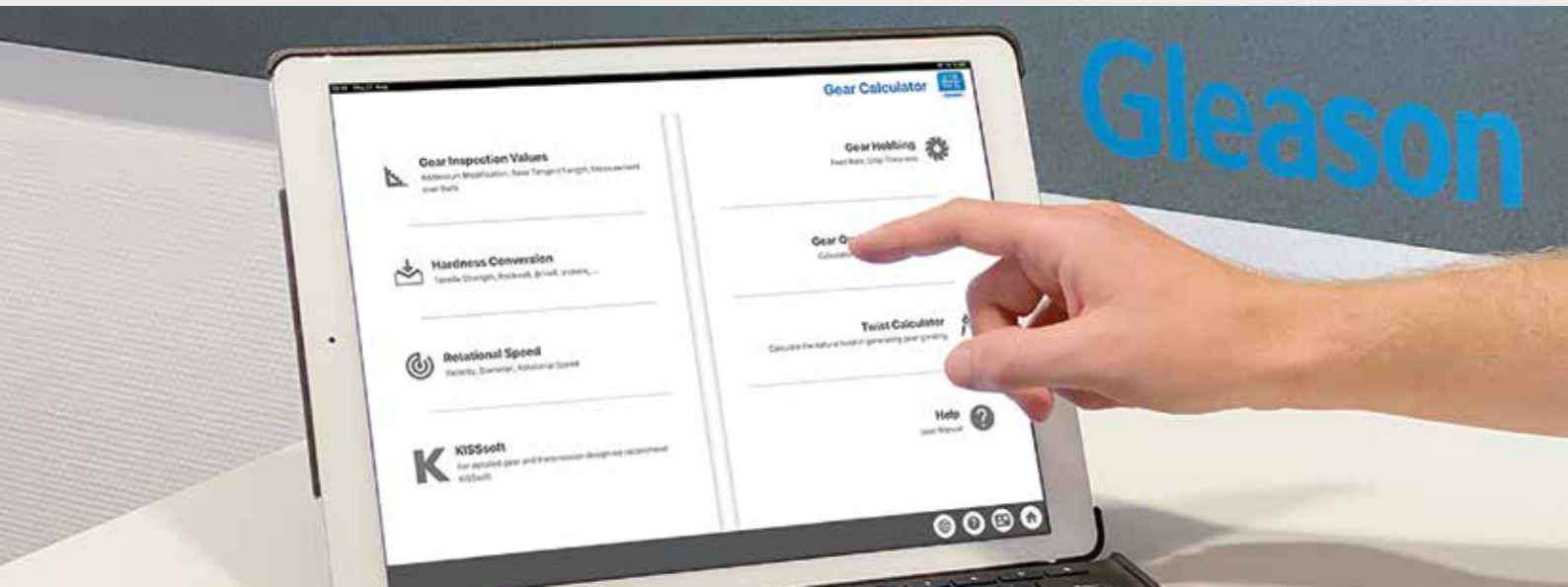

# Gear Calculations: There's an App for That

Gleason's new **Gear Calculator App** simplifies daily tasks, makes your day more efficient.

**G**leason announces its new "Gear Calculator App". This free mobile app bundles simple calculation tools to make the gear manufacturer's daily tasks more efficient and productive. The Gear Calculator toolbox includes calculations for gear inspection values like Addendum Modifications, Base Tangent Lengths and Measurement Over Balls. It provides a hardness converter for tensile strength, Rockwell, Brinell or Vickers; calculates rotational

speeds, deviations within gear quality standards, feed rates and chip thickness when gear hobbing; and even a twist calculator to determine the natural twist for Threaded Wheel Grinding.

The Gear Calculator App works both online and offline, and runs on PCs, notebooks and mobile devices with both Android and iOS. The App must be connected online to install future updates. Please note that you will

need a current browser version to view the Gear Calculator App. When starting the App for the first time it is necessary to register and log into "MyGleason" (for both the PC/notebook version as well as the Mobile App).



**Get the App**

**Gleason**

info@gleason.com  
www.gleason.com

